

FEATURES

- New, cleaner look featuring hidden cord design
- New reinforced base plate for enhanced durability
- Gentle Aerated, Warm Water, Dual Action Spray with cycling movement and massage feature
- Adjustable water temperature and volume
- Warm air drying with three variable temperature settings
- Automatic air deodorizer
- Convenient wireless Remote Control with large LCD panel
- SoftClose® anti-bacterial seat
- Convenient Control Panel
- Heated Seat with Temperature Control
- Docking Station Easy to Install and Clean

MODELS

- SW554 - Elongated front
- SW553 - Round front

- THU9329#01
Traditional style lid (sold separately)
Compatible with SW554#01

COLORS/FINISHES

- Standard
#01 Cotton
#11 Colonial White
#12 Sedona Beige

PRODUCT SPECIFICATION

Seat shall be model # SW554 or # SW553 _____
Seat shall have gentle aerated, warm water, dual action spray with cycling movement and massage feature. Seat shall have adjustable water temperature and volume. Seat shall have warm air drying with three variable temperature settings. Seat shall have automatic air deodorizer. Seat shall include wireless remote control with large LCD panel. Seat shall be solid anti-bacterial plastic with closed front seat and cover. Seat shall include power cord, and water supply hoses.



CODES/STANDARDS

- Meets and exceeds ASME A112.4.2, ASME A112.18.1/CSA B125.1, UL 1431, CSA C22.2 #68
- Certifications: IAPMO(cUPC), Intertek, State of Massachusetts, City of Los Angeles and others
- Code Compliance: UPC, IPC, NSPC, NPC Canada, and others



SPECIFICATIONS

- Power Rating: 120V AC, 60Hz, 410W
- Power Cord: Maximum length: 3.3 ft/100 cm, 3 prong grounded plug
- Water Feature: Adjustable Water Flow Rate:
 - Front washing - from 9.5 - 14.5oz/min.
 - Rear washing - from 9.1 - 14.5 oz/min.
- Washing Spray Temp: Minimum: 86°F/30°C
Maximum: 104°F/40°C
- Water Heater Capacity: 1200W
- Water Heater Tank Volume: 0.30 gal./1.14L
- Safety Device: Thermal fuse, bimetal switch (overheating, auto reset), float switch (no water)
- Back Flow Prevention: Vacuum breaker, One-way Valve
- Drying Feature: Air temperature:
 - High: about 140°F/60°C
 - Medium: about 122°F/50°C
 - Low: about 104°F/40°C
- Dryer Air Capacity: 10.5ft³/min
- Dryer Heater Capacity: 350W
- Seat Warming Feature: Surface Temperature:
 - Minimum: 81°F/27°C
 - Maximum: 97°F/36°C
- Seat Heater Capacity: 50W
- Safety Device: Thermal fuse
- Water Supply Pressure: Minimum: 20 psi
Maximum: 80 psi
- Ambient Temperature: Range: 33°F/1°C to 104°F/40°C
- Weight: Net: 11.5 lbs/5.2 kg
Gross: (w/pkg) 17.4lbs/7.9kg
- Product Dimensions: 15-3/4" W x 20-15/16" D x 5-1/8" H (elongated)
15-3/4" W x 19-3/4" D x 5-1/8" H (round)
- Warranty: One Year Limited Warranty
- Shipping weight: 12lbs.
- Shipping dimensions: 16" x 21" x 6"

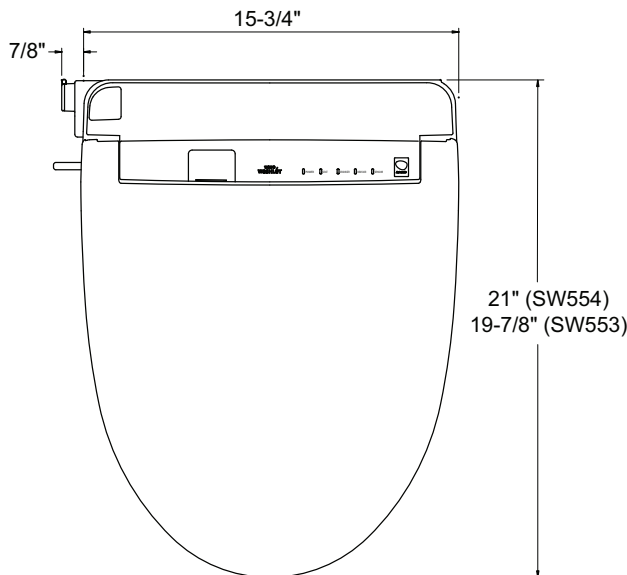

INSTALLATION NOTES

- Washlet S300 may not fit certain toilet bowl designs.
- If possible, with your order, please include your toilet manufacturer's name and model number (from the underside of the tank lid).